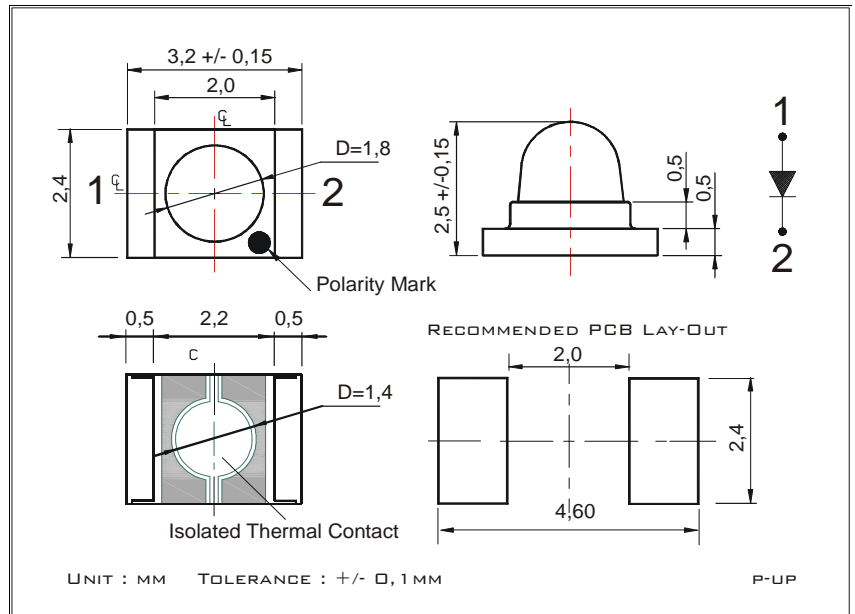

IR-LED**870nm****FQM5551ADA****Features**

- * Standard design LED for general purpose
Based on GaAlAs
- * Fast switching time : typical <40ns
- * mechanical matched with photodiodes
CSM3851OT40 /FSM3851 or
phototransistor CSM 3831OHK
- * High power for SMD case with 15°full angle
- * Water-clear package style
- * Application : Open-Air communication / IrDa
 IR-Flash-Lights
 Medical instruments
 Light interrupter and switches

**Electrical and optical characteristics and absolute maximum ratings (Ta=25°C unless otherwise noted)**

Symbol	Parameter	MIN	Typ	MAX	Unit	Test conditions
I _F	DC Forward current		60	80	mA	
I _{PEAK}	Peak Forward current			800	mA	T _p < 10μsec. ; T=1:100 ; R _{therm} < 100 K/W
V _F	Forward Voltage	1,35		2,10	V	I _F = 150mA @ T _p =1ms
V _R	Reverse Voltage	5			V	I _{rev} = 100μA
λ _{Peak}	Peak Wavelength	860	870	880	nm	I _F = 50mA
Δλ _{0,5}	Bandwidth of half power	25	30		nm	I _F = 50mA
t _f	Fall time		30	40	ns	I _F = 80mA
t _r	Rise time		30	40	ns	I _F = 80mA
Φ _E	Total Power Output	36	46		mW	I _F = 80mA
I _E	Radiant Intensity	30	60		mW/sr	I _F = 80mA
2Φ _{0,5}	Emission Angel	10	15	17	deg.	Φ _E = 50%
TK _{VF}	Temp.Coeff. of Forward Voltage		- 2		mV/K	
TK _F	Temp.Coeff. of Radiant Power		- 0,4		%/K	
T _{Operating}	Operating Temperature	- 25		85	°C	
T _{Storage}	Storage Temperature	- 25		85	°C	
T _{Soldering}	Soldering Temperature			235	°C	@5 sec.
Θ _{j-PIN}	Thermal Resistance		450		K/W	
P _{tot}	Total Power Dissipation			130	mW	derate above 45°C 3mW/K

Order Informations :**FQM5551ADA-TR** Tape&Reel (1500 pcs./Reel; lens top in the tape)

Fietje reserves the right to make changes at any time in order to improve design and to supply the best product possible, contact Fietje for latest device specification sheets before using.

IR-LED

FQM551ADA

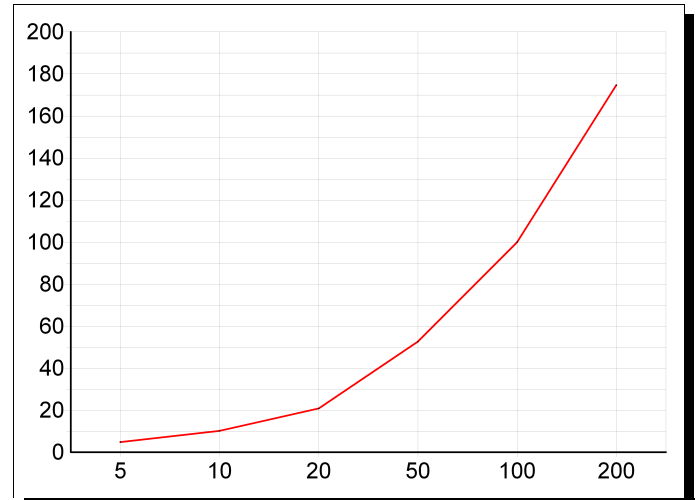
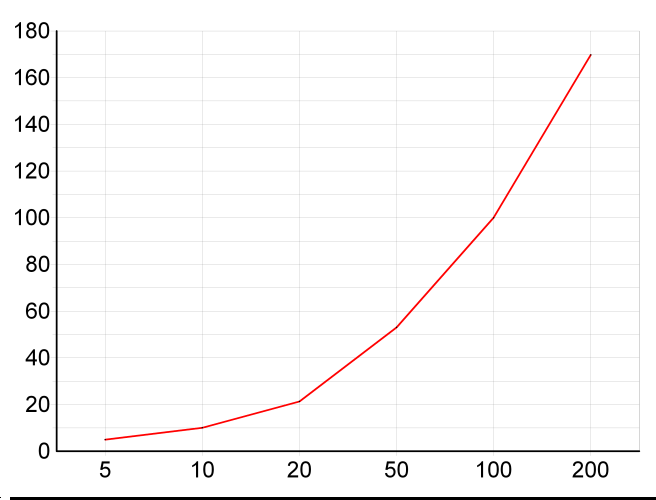
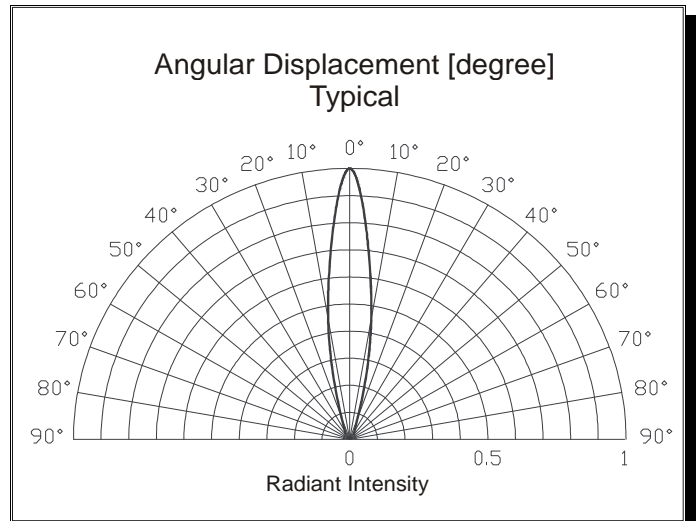
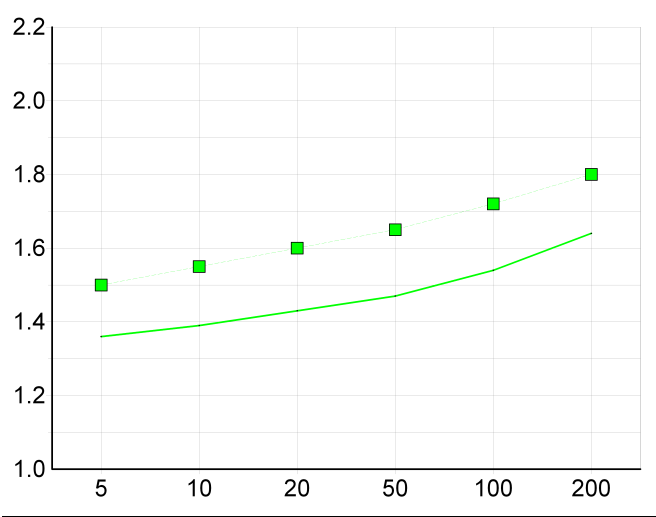
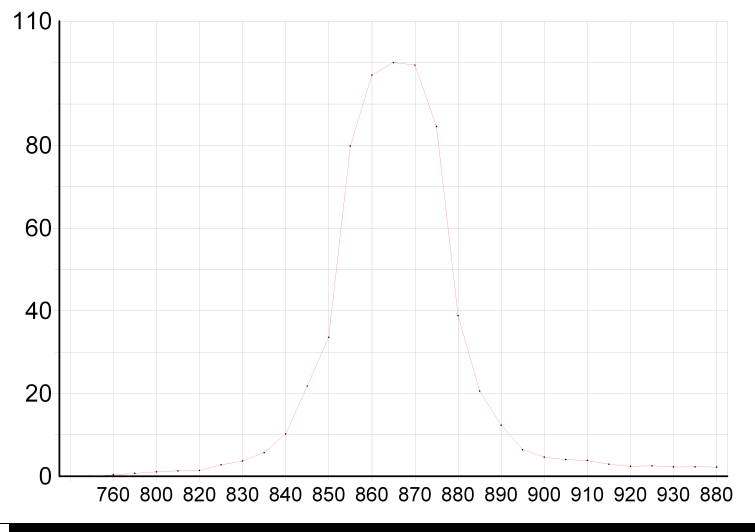

Tape : Cathode is undepend on the polarity mark on the side of transportation lane

Fietje reserves the right to make changes at any time in order to improve design and to supply the best product possible, contact Fietje for latest device specification sheets before using.

FIETJE SENSOR&OPTOELEKTRONIK GMBH

WWW.FIETJE-WEB.DE

E-MAIL : SALE.INFO@FIETJE-WEB.D