

DualWavelength LED

870nm/505nm FQR4802

Features

- * Standard design LED for special purpose
Based on double hetero structure of GaAlAs
- * 1.LED=870nm / 2. LED = 505nm
- * Water-clear package style with stand-off
- * Three lead T1 3/4 case with serial connected Chips
- * Application : Spectral analysis
 IR/Green-Flash-Lights
 Medical instruments
 CCD-Illumination

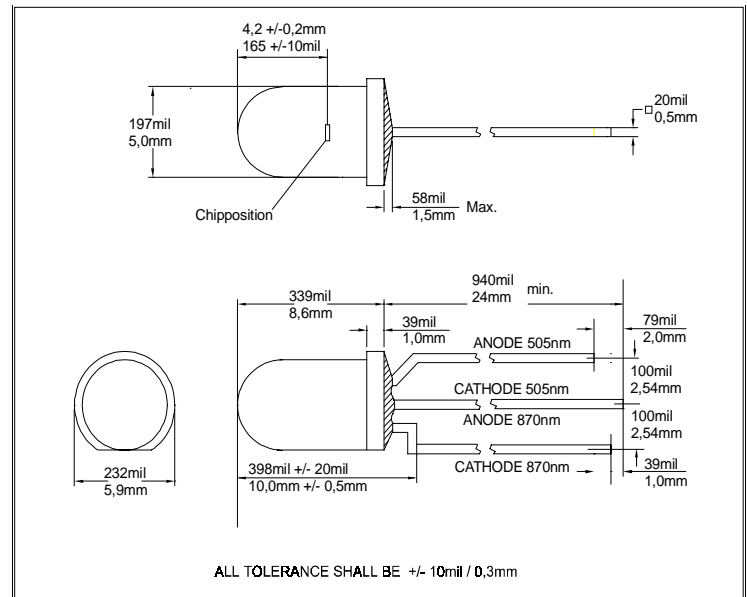

Electrical and optical characteristics and absolute maximum ratings (Ta=25°C unless otherwise noted)

Symbol	Parameter	MIN	Typ	MAX	Unit	Test conditions
I _F	DC Forward current			100	mA	1. LED
I _F	DC Forward current			25	mA	2. LED
I _{PEAK}	Peak Forward current 1. LED			1000	mA	T _p < 10µsec. ; T=1:100 ; R _{therm} < 100 K/W
I _{PEAK}	Peak Forward current 2. LED			75	mA	T _p < 10µsec. ; T=1:100 ; R _{therm} < 100 K/W
V _F	Forward Voltage	1,3	1,4	2,1	V	I _F = 50mA 1.LED
V _F	Forward Voltage		3,5	4	V	I _F = 20mA 2.LED
V _R	Reverse Voltage	4			V	I _{rev} = 100µA 1.LED/ 2.LED
λ _{Peak}	Peak Wavelength	860	870	890	nm	I _F = 50mA 1.LED
λ _{Peak}	Peak Wavelength	500	505	510	nm	I _F = 20mA 2.LED
Δλ _{0,5}	Bandwidth of half power	25	30		nm	I _F = 50mA , both LED's
t _{f/r}	Fall time / Rise time		20		ns	I _F = 100mA 1.LED
t _{f/r}	Fall time / Rise time		500		ns	I _F = 100mA 2.LED
F _E	Total Power Output	10	20		mW	I _F = 50mA 1.LED
I _E	Radiant Intensity	45	90		mW/sr	I _F = 50mA 1.LED
F _E	Total Power Output		TDB		mW	I _F = 20mA 2.LED
I _v	Luminous intensity	850	1500		mcd	I _F = 20mA 2.LED
2Φ _{0,5}	Emission Angel horizontal		30		deg.	Φ _E / I _v = 50%; I _F =20mA
2Φ _{0,5}	Emission Angel vertical		30		deg.	Φ _E / I _v = 50%; I _F =20mA
TK _{VF}	Temp.Coeff. of Forward Voltage		- 2		mV/K	
TK _F	Temp.Coeff. of Radiant Power		- 0,4		%/K	
T _{Operating}	Operating Temperature	- 25		85	°C	
T _{Storage}	Storage Temperature	- 25		85	°C	
T _{Soldering}	Soldering Temperature			260	°C	5mm from case @ 5 sec.
Θ _{j-PIN}	Thermal Resistance		450		K/W	
P _{tot}	Total Power Dissipation			230	mW	derate above 45°C 2,5mW/K

Order Informations :

Asked us for : FQR4802 Bulk
 FQR4802TR Taped on Reel / 1000 pcs. standard reel

Fietje reserves the right to make changes at any time in order to improve design and to supply the best product possible, contact Fietje for latest device specification sheets before using.