

Infrared Light Emitting Diode IRED

870nm/20ns FQR5507

Features

- * Standard design LED for general purpose
Based on double hetero structure of GaAIAs
- * Fast switching time : typical <20ns
- * High cut-off frequency of >20Mhz @-3dB
- * Medium power for T1 3/4 case
with 40° full beam angle
- * Water-clear package style without stand-off
- * Application : Open-Air communication / IrDa
IR-Flash-Lights
Medical instruments
Light interrupter and switches

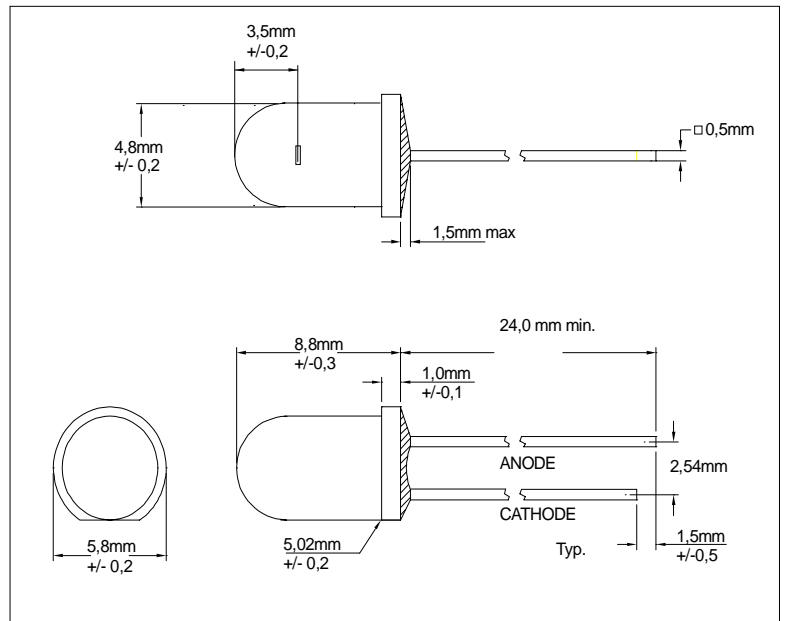

Electrical and optical characteristics and absolute maximum ratings (Ta=25°C unless otherwise noted)

Symbol	Parameter	MIN	Typ	MAX	Unit	Test conditions
I _F	DC Forward current			100	mA	
I _{PEAK}	Peak Forward current			1500	mA	T _p < 10µsec. ; T=1:100 ; R _{therm} < 100 K/W
V _F	Forward Voltage FQR5507	1,3	1,5	1,9	V	I _F = 150mA T _p =1ms
V _F	Forward Voltage FQR5507	1,3	1,4	1,65	V	I _F = 100mA
V _R	Reverse Voltage	5			V	I _{rev} = 100µA
λ _{Peak}	Peak Wavelength	860	870	885	nm	I _F = 50mA
Δλ _{0,5}	Bandwidth of half power	25	30		nm	I _F = 50mA
t _f	Fall time		20		ns	I _F = 100mA
t _r	Rise time		20		ns	I _F = 100mA
F _E	Total Power Output	22	27		mW	I _F = 100mA
I _E	Radiant Intensity	31	39		mW/sr	I _F = 100mA
D	Diameter of light emitting point		4		mm	I _F = 20mA, 63% of radiant output (IEC825)
A	Chip size		0,13		mm ²	Chip size : 360µmX360µm
2Φ _{0,5}	Emission Angel		40	45	deg.	Φ _E = 50%
TK _{VF}	Temp.Coeff. of Forward Voltage		- 2		mV/K	
TK _F	Temp.Coeff. of Radiant Power		- 0,4		%/K	
T _{Operating}	Operating Temperature	- 25		85	°C	
T _{Storage}	Storage Temperature	- 25		85	°C	
T _{Soldering}	Soldering Temperature			260	°C	2mm from case @ 5 sec.
Θ _{j-PIN}	Thermal Resistance		450		K/W	
P _{tot}	Total Power Dissipation			230	mW	derate above 45°C 2,5mW/K

Order Informations :

FQR5507 Bulk
FQR5507TR Tape on reel/1000pcs.

Fietje reserves the right to make changes at any time in order to improve design and to supply the best product possible, contact Fietje for latest device specification sheets before using.

Infrared Light Emitting Diode IRED

870nm/20ns FQR5507

