

## Infrared LED

## 850nm

## FQR61592BAP

### Features

- \* Very narrow beam LED with typ. 4° full angle
- \* Standard design LED for general purpose
- \* Fast switching time : typical <25ns
- \* SMT-Version tape&reeled for automatic placing FQS61592BAP
- \* Water-clear package style mountable in 5,0 mm rast
- \* High radiant power at very low current
- \* Spectral and mechanical matched to FSR68XX - serie Phototransistor and FSS78XX and FSS79XX photodiodes
- \* Application : Open-Air communication / IrDa  
Battery driven applications  
Medical instruments  
Light interrupter, switches and IR-vision control flash-lights

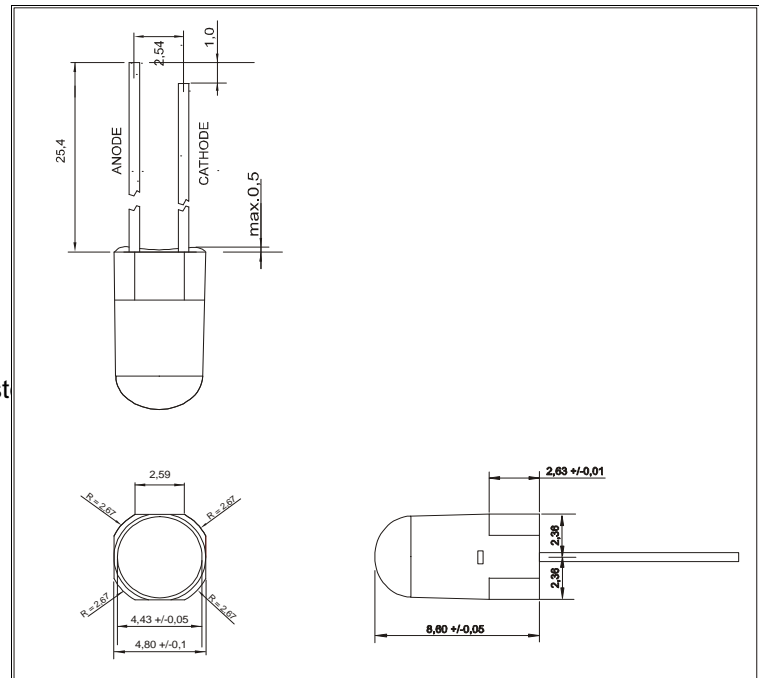

### Electrical and optical characteristics and absolute maximum ratings ( Ta=25°C unless otherwise noted )

Symbol	Parameter	MIN	Typ	MAX	Unit	Test conditions
I <sub>F</sub>	DC Forward current	1	75	100	mA	
I <sub>PEAK</sub>	Peak Forward current			750	mA	T <sub>p</sub> < 10μsec ; T = 1:100 ; R <sub>therm</sub> < 100 K/W
V <sub>F</sub>	Forward Voltage	1,3	1,5	2,1	V	I <sub>F</sub> = 100mA
V <sub>R</sub>	Reverse Voltage	5			V	I <sub>rev</sub> = 100μA
λ <sub>Peak</sub>	Peak Wavelength	840	850	860	nm	I <sub>F</sub> = 50mA
Δλ <sub>0,5</sub>	Bandwidth of half power	25	30		nm	I <sub>F</sub> = 50mA
t <sub>f</sub>	Fall time		35		ns	I <sub>F</sub> = 100mA
t <sub>r</sub>	Rise time		35		ns	I <sub>F</sub> = 100mA
Φ <sub>E</sub>	Total Power Output	50	58		mW	I <sub>F</sub> = 100mA
I <sub>E</sub>	<b>Radiant Intensity</b>	<b>1000</b>	<b>4300</b>	<b>7000</b>	<b>mW/sr</b>	<b>I<sub>F</sub> = 100mA</b>
2Φ <sub>0,5</sub>	Emission Angel	3	4	5	deg.	Φ <sub>E</sub> = 50% @50mA
TK <sub>VF</sub>	Temp.Coeff. of Forward Voltage		- 2		mV/K	
TK <sub>F</sub>	Temp.Coeff. of Radiant Power		- 0,4		%/K	
T <sub>Operating</sub>	Operating Temperature	- 25		85	°C	
T <sub>Storage</sub>	Storage Temperature	- 25		85	°C	
T <sub>Soldering</sub>	Soldering Temperature			260	°C	2mm from case @5 sec.
Θ <sub>j-PIN</sub>	Thermal Resistance		450		K/W	
P <sub>tot</sub>	Total Power Dissipation			230	mW	derate above 45°C 5mW/K

Order Informations :

FQR61592BAP-XX--BU

Bulk (1000 pcs./Bag)

**Attention : This product can generate a high level risks for human eyes and body acc. IEC 825 and EN62471 !**

Fietje reserves the right to make changes at any time in order to improve design and to supply the best product possible, contact Fietje for latest device specification sheets before using.

FIETJE SENSOR&OPTOELEKTRONIK GMBH

WWW.FIETJE-WEB.DE

E-MAIL : SALE.INFO@FIETJE-WE

DESIGNED AND ALL RIGHTS RESERVED BY LEDESIGN ENGINEERING

**Infrared LED**

**850nm**

**FQR61592BAP**

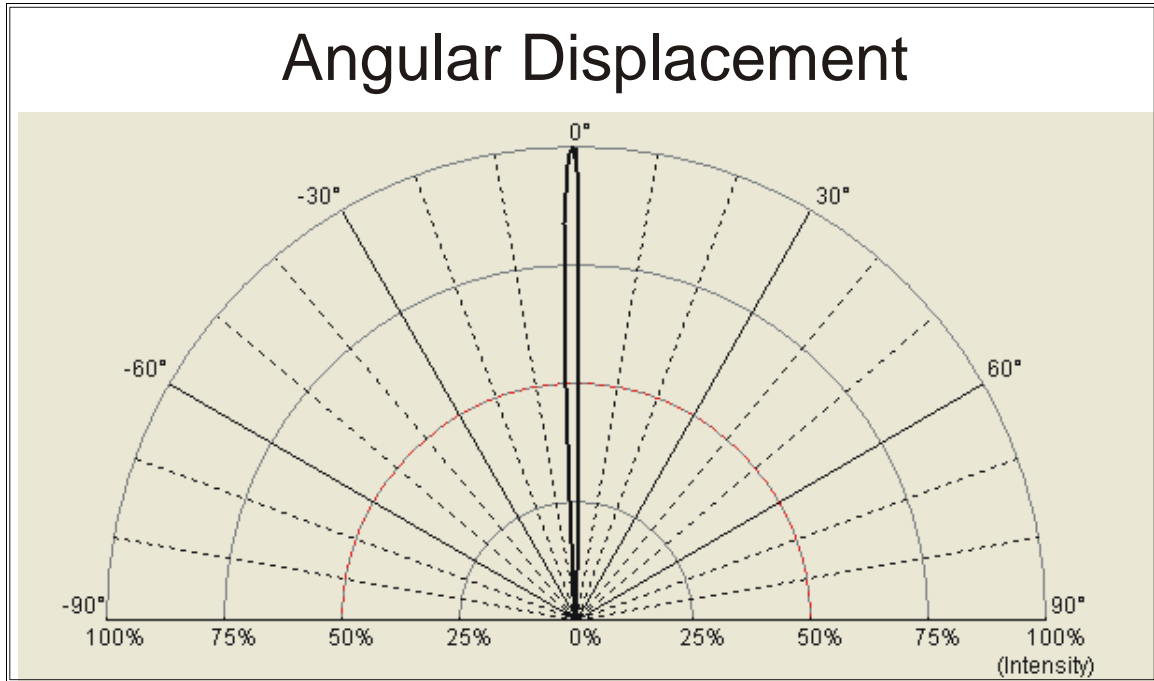

**Pls. contact us for more technical detail informations !**

**Attention : This product can generate a high level risks for human eyes and body acc. IEC 825 and EN62471 !**

Fietje reserves the right to make changes at any time in order to improve design and to supply the best product possible, contact Fietje for latest device specification sheets before using.

FIETJE SENSOR&OPTOELEKTRONIK GMBH

WWW.FIETJE-WEB.DE

E-MAIL : SALE.INFO@FIETJE-WE

DESIGNED AND ALL RIGHTS RESERVED BY LEDESIGN ENGINEERING