

Phototransistor

18°

FSR3852-FSR3854

Features

- * 4.8mm Phototransistor with separate Base for general purpose
- * High responsivity with typ. 0,55 A/W
- * Daylight filtered black housing
- * Mechanical matched with FQR5553
- * Mountable in row with 5mm distance
- * Narrow viewing angle of typ. 18 degree

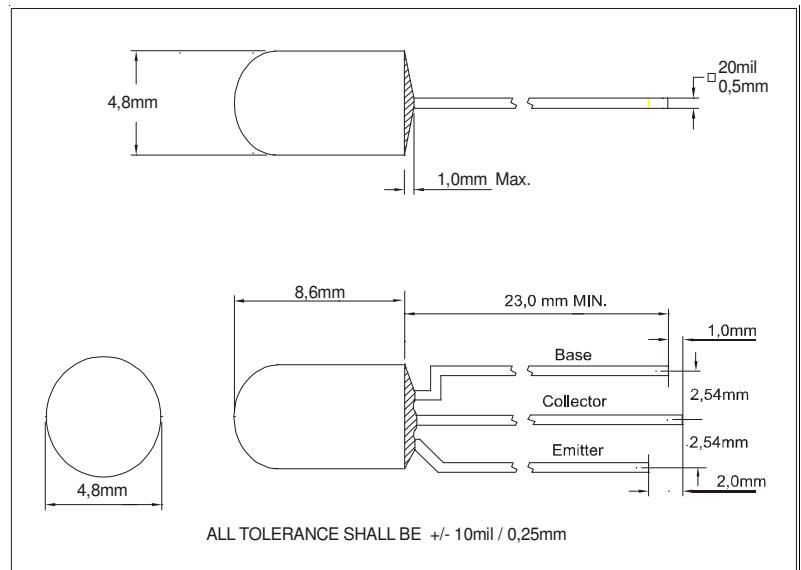

Electrical and optical characteristics and absolute maximum ratings (Ta=25°C unless otherwise noted)

Symbol	Parameter	MIN	Typ	MAX	Unit	Test conditions
I _{Light}	Light Current FSR3852	3	5		mA	V _{ce} =10V; E _e = 0.5mW/cm ² ; @940nm
I _{Light}	Light Current FSR3853	3,7	6		mA	V _{ce} =10V; E _e = 0.5mW/cm ² ; @940nm
I _{Light}	Light Current FSR3854	4	7		mA	V _{ce} =10V; E _e = 0.5mW/cm ² ; @940nm
I _{ceo}	Collector Dark Current			100	nA	V _{ce0} =10V; E _v =0
V _{bceo}	Collector-Emitter Breakdown Voltage	30			V	I _c = 100μA H=0mW/cm ²
V _{beco}	Collector-Emitter Breakdown Voltage	5			V	I _c = 100μA H=0mW/cm ²
V _{sat}	Collector-Emitter Saturation Voltage			0,3	V	I _b = 100μA I _c =2mA
λ _{Peak}	Peak Wavelength		860		nm	max. sensitivity
λ _{0,5}	Spectral range	700		1150	nm	I=10%
t _f	Fall time		15		μs	V _R =5V; R _L =1KOhm, I _c =1mA
t _r	Rise time		15		μs	V _R =5V; R _L =1KOhm, I _c =1mA
A	Active Array		0,146		mm ²	
β	Current Gain FSR3852	500		1000		V _{ce} =5V; I _c =2mA
β	Current Gain FSR3853	800		1300		V _{ce} =5V; I _c =2mA
β	Current Gain FSR3854	1000		1800		V _{ce} =5V; I _c =2mA
2Φ _{0,5}	Response Angle		18		deg.	Φ _i = 50%
C _J	Junction Capacity		6		pF	V _R =0V; f=1 MHz; E _v =0 Lux
T _{Operating}	Operating Temperature	-25		85	°C	
T _{Storage}	Storage Temperature	-25		100	°C	
T _{Soldering}	Soldering Temperature			260	°C	5mm from case @5 sec.
Θ _{j-PIN}	Thermal Resistance		450		K/W	
P _{tot}	Total Power Dissipation			50	mW	

Order Informations :

FSR3852 Bulk
FSR3853 Bulk
FSR3854 Bulk

Fietje reserves the right to make changes at any time in order to improve design and to supply the best product possible, contact Fietje for latest device specification sheets before using.

Phototransistor

18°

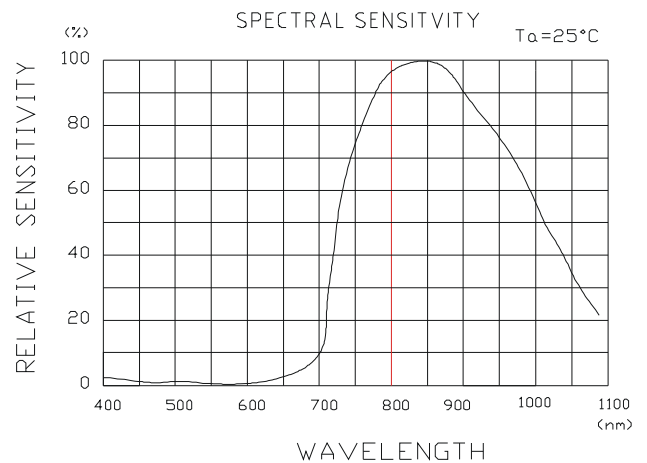
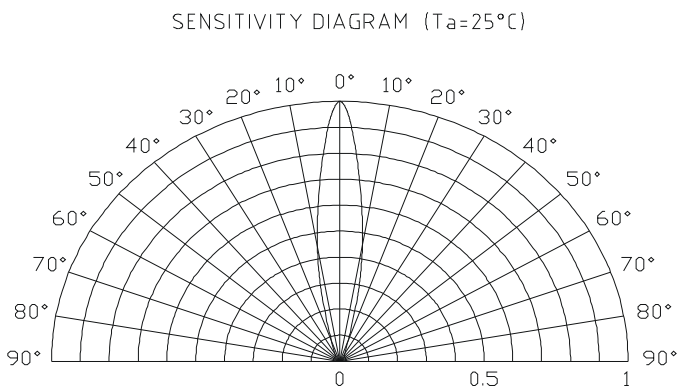
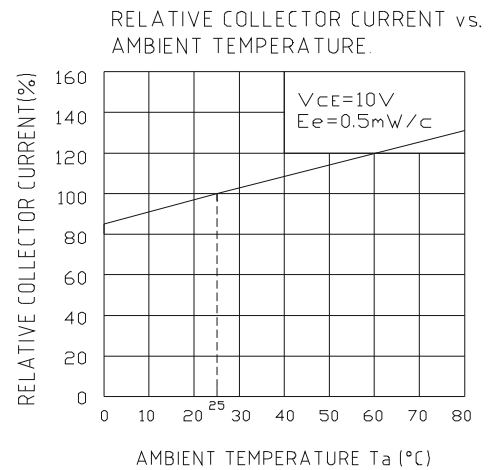
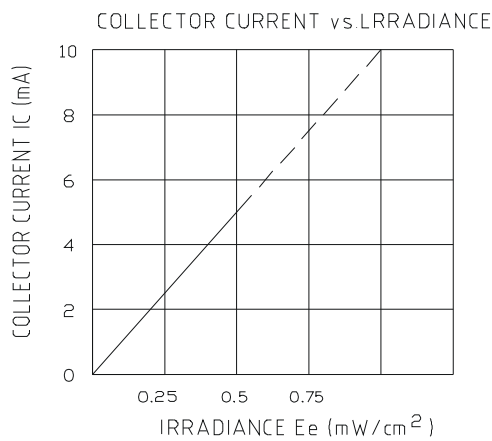
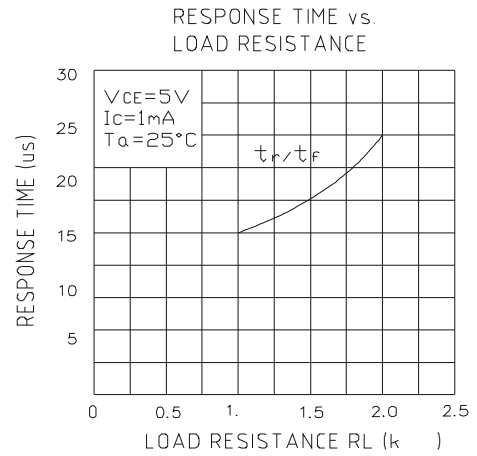
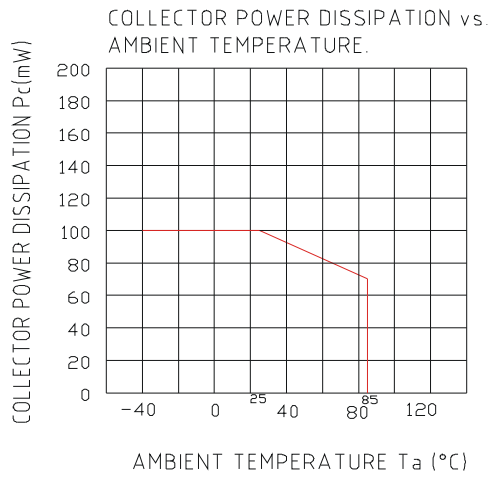

Datenblatt_FSR3853/3854

05-Mai-09

Fietje reserves the right to make changes at any time in order to improve design and to supply the best product possible, contact Fietje for latest device specification sheets before using.